

LED Highbay Lights Series

Main Features

- CREE XML LED, high luminous efficiency and long life
- MEAN WELL high efficiency LED driver
- Universal voltage AC90-277V, AC347-528V available
- Fins cooling design, better cooling light quality, LED $T_j < 85^\circ\text{C}$
- Excellent optical design, greatly improve the light utilization and evenness.
- ETL、DLC、CE、RoHS certified
- 5years warranty

Model Number

LS-HHBC100W

LS-HHBC120W

LS-HHBC150W

LS-HHBC200W



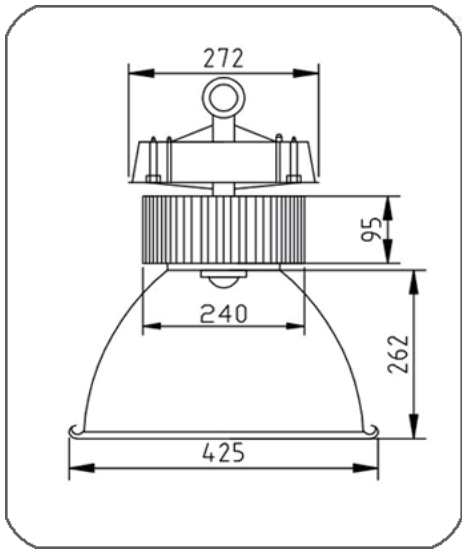

LS-HHBC100W

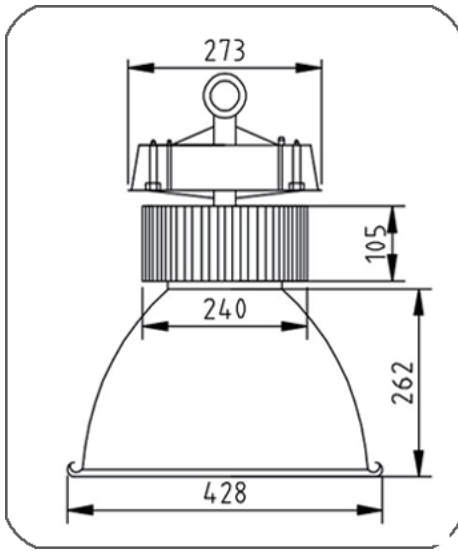

LS-HHBC120W /150W

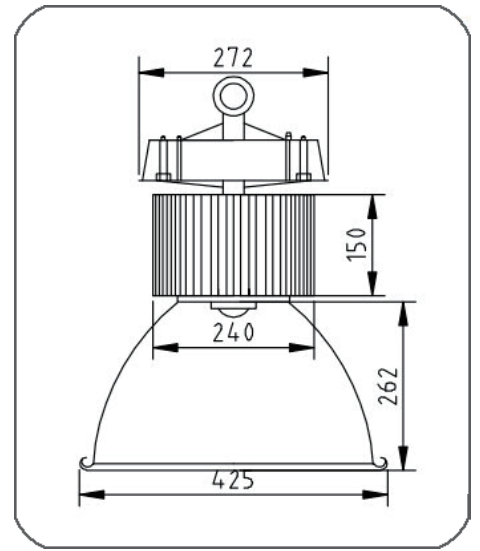

LS-HHBC200W

Reflectors Available

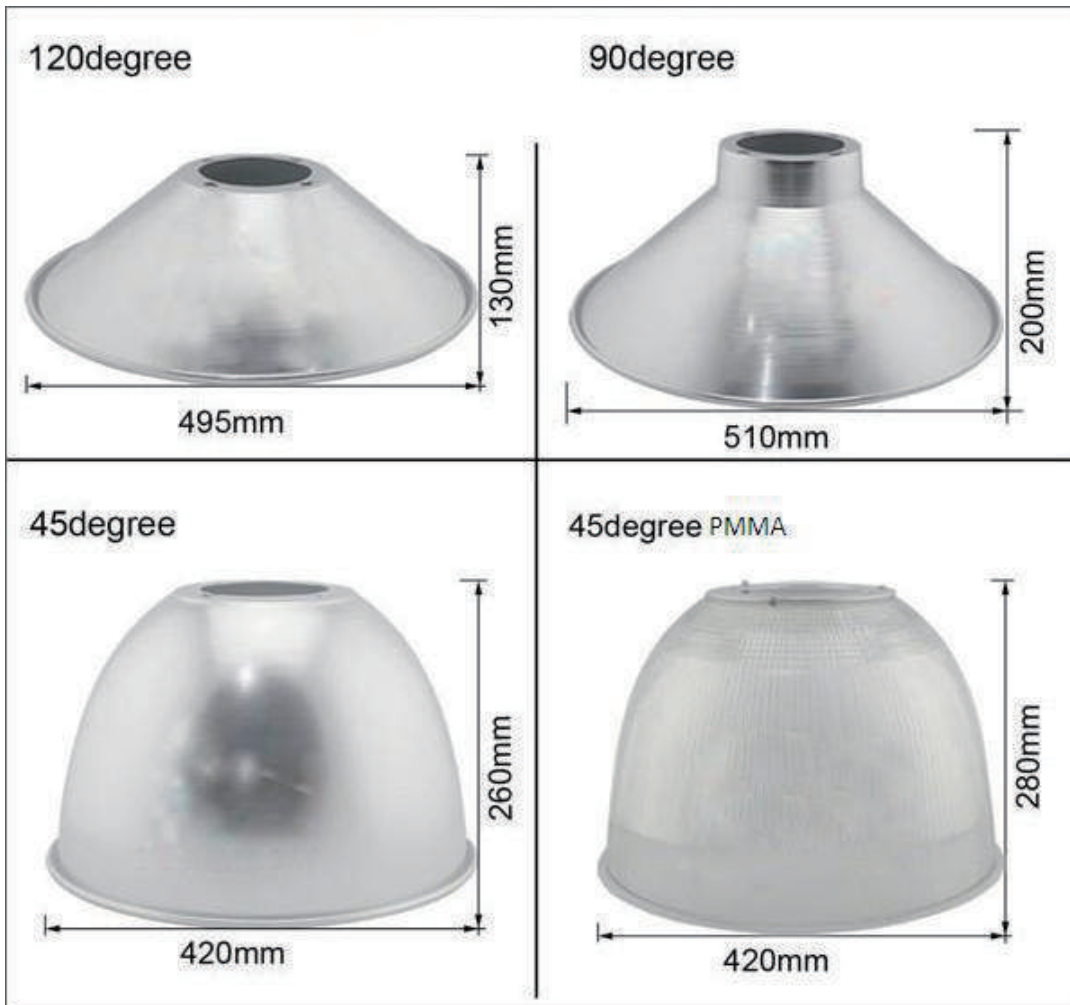

Luminous Intensity Distribution(C)

UNIT:cd

— V 0.0DEG PLAN
— H 0.0DEG PLAN

BeamAngle(50%):129.0 Deg

BeamAngle(10%):147.0 Deg

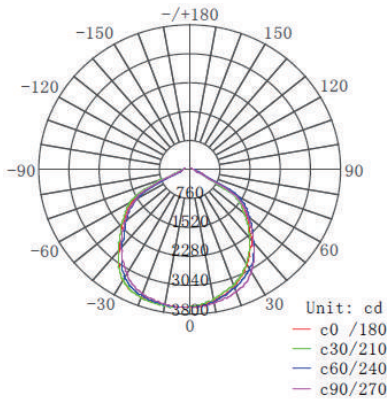

LS-HHBC100W

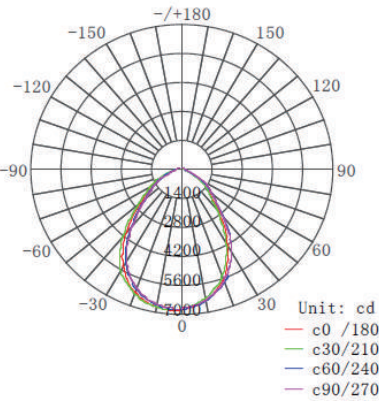

LS-HHBC120W

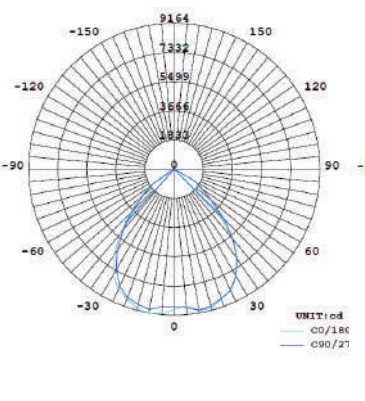

LS-HHBC150W

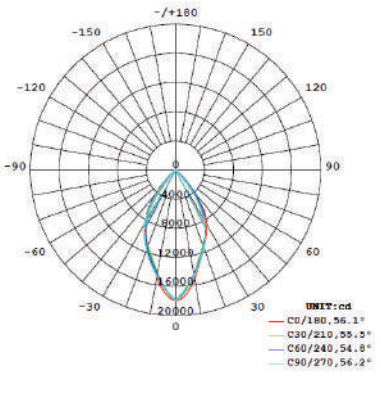

LS-HHBC200W

Main Parameters

Model#	LS-HHBC100W	LS-HHBC120W	LS-HHBC150W	LS-HHBC200W
Power	100W	120W	150W	200W
Output Lumen	10000lm	12000lm	15000lm	20000lm
Certificate	ETL CE RoHS	ETL DLC CE RoHS		DLC CE RoHS
Voltage	90~277VAC (180V-528VAC available)			
LED/Driver brand	CREE XML LED/MEAN WELL Driver			
Material of Heat sink	Die-casting aluminum			
Material of Diffuser Lens	Optical Glass			
CCT	3000K-6500K			
Beam Angel	129Deg.(50%) 147Deg.(10%)			
PF	>0.9			
CRI	≥75			
IP Rating	IP65			
Color of heat sink and driver box available	Black and Silvery			
Working Temperature	-22°F ~140°F /-30°C ~60°C			
Lifespan	>50,000hrs			

Applications

LED highbay lights are used in workshops, factories, warehouse, toll stations, gas stations, supermarket, exhibition halls, gymnasiums, etc..

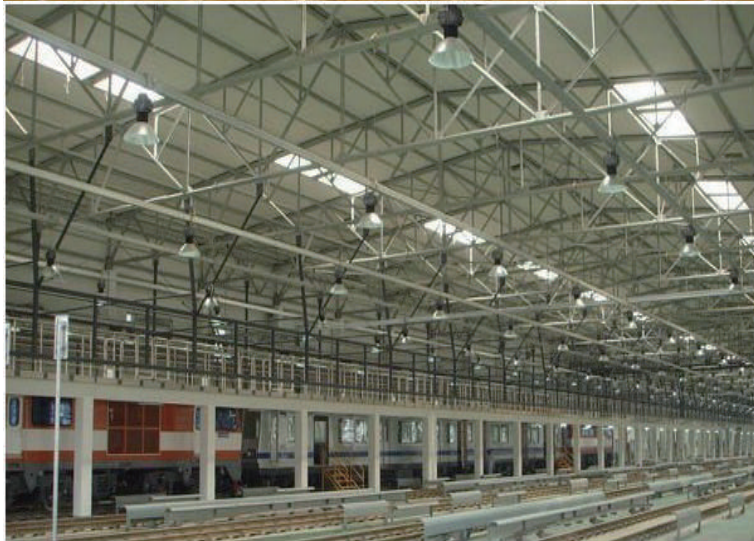

Contact Us