



TIEXING HONGYUN USA CO.
LED DIVISION



Technical Application
Guide for UP-SHINE
LED Panel Light

UP-PL2X2-50W

UP-PL2X2-50WD

Introduction



Up-shine LED troffer adopts LM-80 SMD led chip, with UL&cUL, DLC approved for North America market. 1X4, 2X2, 2X4 sizes are available for various demand. Branded led driver with top quality component ensures long life time. 0-10V dimmable and non-dimmable version both provided.

The ultra slim profile fits seamlessly into any workplace.

- Up to 80% energy saving compared to standard CFL
- Long lifetime of 50,000 hours
- 0-10V dimmable with MeanWell dimmable driver
- 120° wide beam angle
- 603x603mm cutout
- CCT: 2700K 3000K
4000K 5000K
- No UV/IR light
- Environment friendly, without Mercury or any other hazardous substances

Application notes

- IP40 for indoor use
- Professional electrician for installation only
- Switch off before installation
- Do not touch when in use
- Keep away from hot steam and corrosive gas

Application Areas

Widely used for various commercial lighting and residential lighting applications, such as offices, shopping mall, hotel, restaurant, hospital, home lighting etc.

Certificates



Product Information

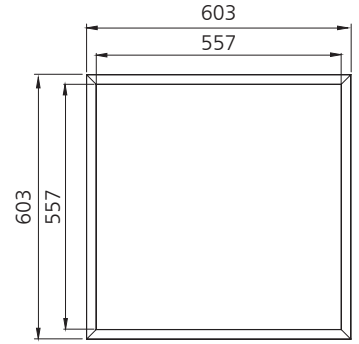
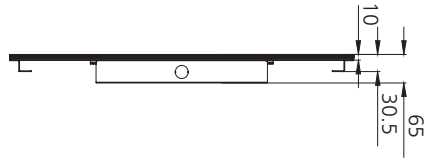

Technical Specifications

Model	Voltage	Power	Power Factor	Lumen (±5%)	Beam angle	CCT	Lifespan	CRI	Dimmable	Dimension
UP-PL2X2-50W	AC100-277V	50W	≥0.9	4250	120°	2700K	50000h	≥80	No	603*603*10mm
UP-PL2X2-50W	AC100-277V	50W	≥0.9	4300	120°	3000K	50000h	≥80	No	603*603*10mm
UP-PL2X2-50W	AC100-277V	50W	≥0.9	4350	120°	4000K	50000h	≥80	No	603*603*10mm
UP-PL2X2-50W	AC100-277V	50W	≥0.9	4400	120°	5000K	50000h	≥80	No	603*603*10mm
UP-PL2X2-50WD	AC100-277V	50W	≥0.9	4350	120°	2700K	50000h	≥80	Yes	603*603*10mm
UP-PL2X2-50WD	AC100-277V	50W	≥0.9	4400	120°	3000K	50000h	≥80	Yes	603*603*10mm
UP-PL2X2-50WD	AC100-277V	50W	≥0.9	4450	120°	4000K	50000h	≥80	Yes	603*603*10mm
UP-PL2X2-50WD	AC100-277V	50W	≥0.9	4500	120°	5000K	50000h	≥80	Yes	603*603*10mm

Driver data Sheet

Driver data	DIM	Non-dim
Input rated Voltage	AC100-277V	AC100-277V
Frequency	50/60Hz	50/60Hz
Input Voltage	AC90-305V	AC90-305V
Efficiency	≥90%	≥85%
Total load Wattage	45W±5%	50W±5%
Power Factor	≥0.9	≥0.9
Rated input current	≤0.5A	≤0.6A
Full load output Voltage	DC23-26V	DC23-26V
Rated output current	1800mA	1750mA
Output current range	1800mA±5%	1750mA±5%
Power tolerance	±5%	±5%
Current output tolerance	±5%	±5%
Dimming range	1%-100%	—
Dimmer	0V-10V dimmer	—
Short circuit protection	PASS	PASS
Over voltage protection	PASS	PASS
Over temperature protection	PASS	PASS
Withstand voltage	AC3750V	AC3750V

Fixture Compatibility

Rated Wattage	Electrical Classification	Ingress Protection	Operating Temp	Operating Humidity	Storage Temp
50W	II	IP40	-20°C-45°C	0-90%	-20°C-65°C

Spectral Distribution

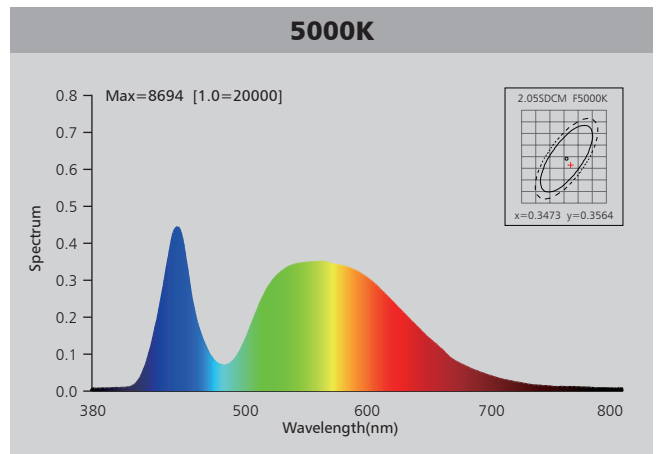
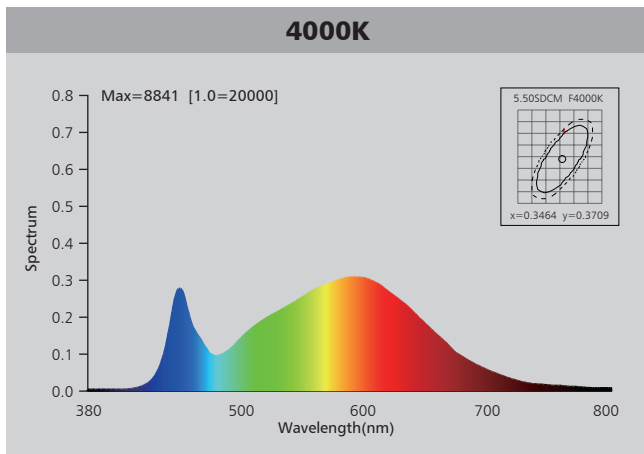
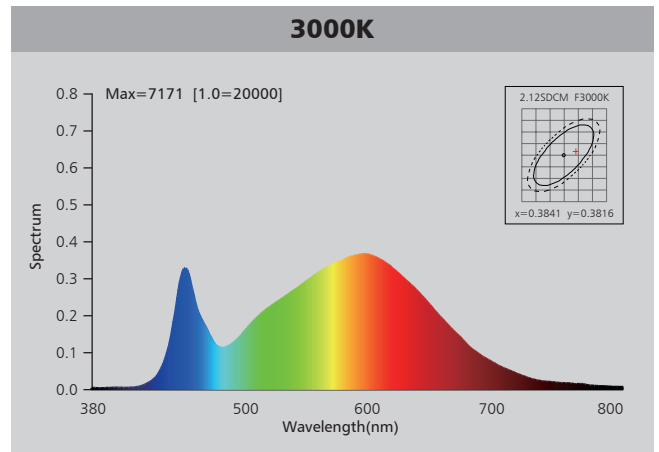
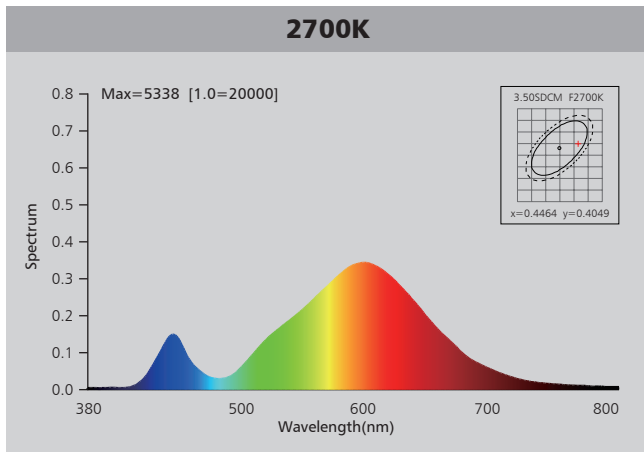

Photometric Diagram

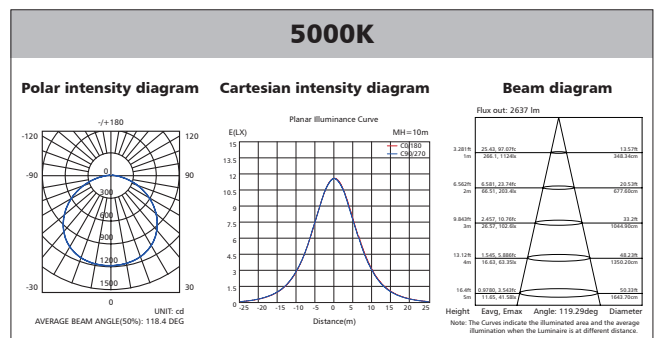
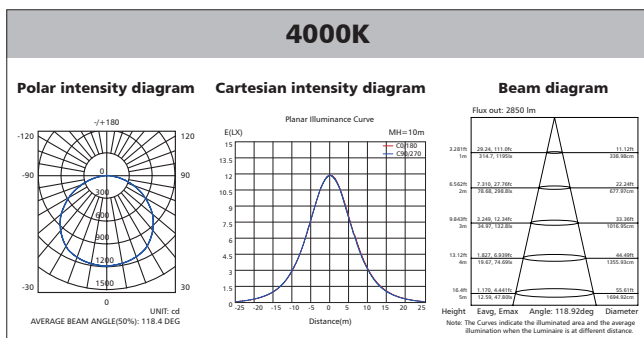
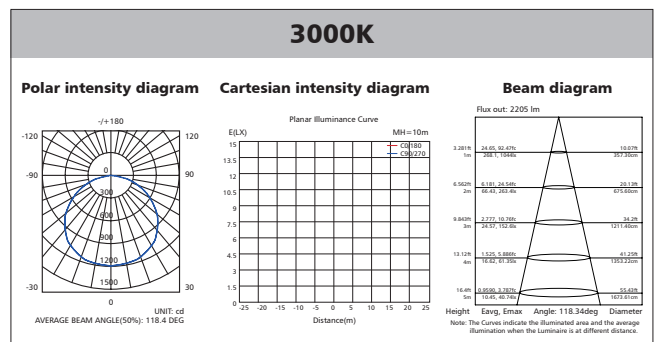
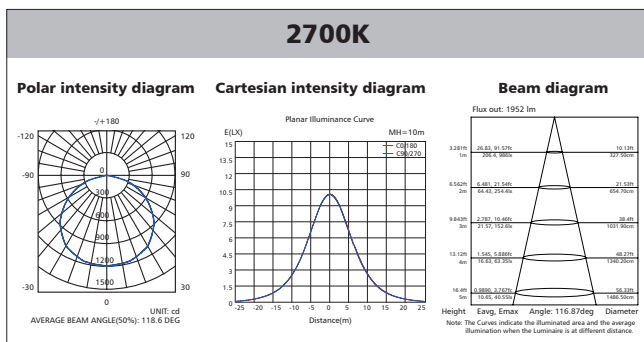

Polar Diagram Comparison

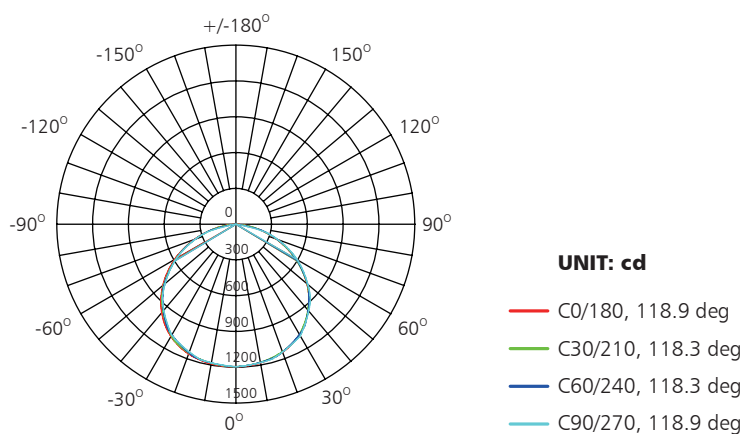

AVERAGE BEAM ANGLE (50%): 118.6DEG



Driver lifetime & LED light decay rate

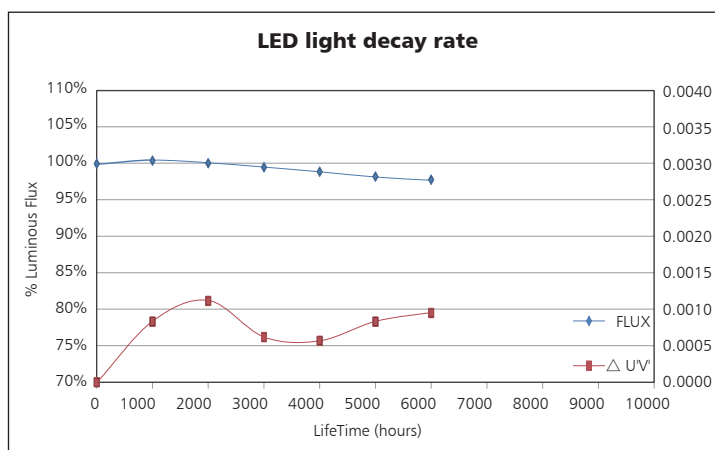
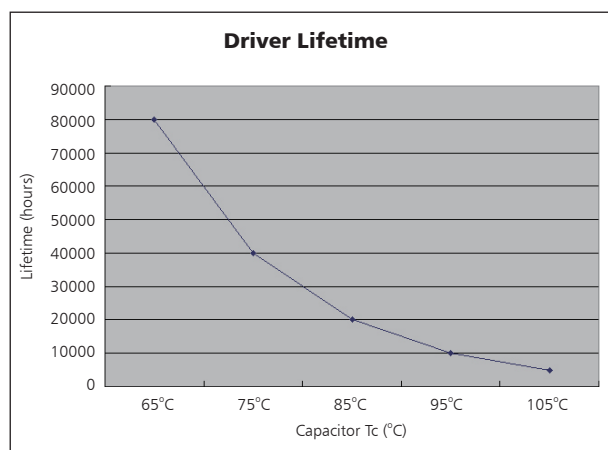

Temperature

- The testing is operated at 25°C
- The lifetime of capacitor, minimum of 5,000 hours if operated at 105°C, will be doubled whenever the temperature drops 10°C. Working at 75°C or below, the lamp can achieve its maximum lifetime of 40,000 hours.
- The highest withstand temperature of IC, MOS could be 120°C
- The highest withstand temperature of LED junction temperature is 150°C

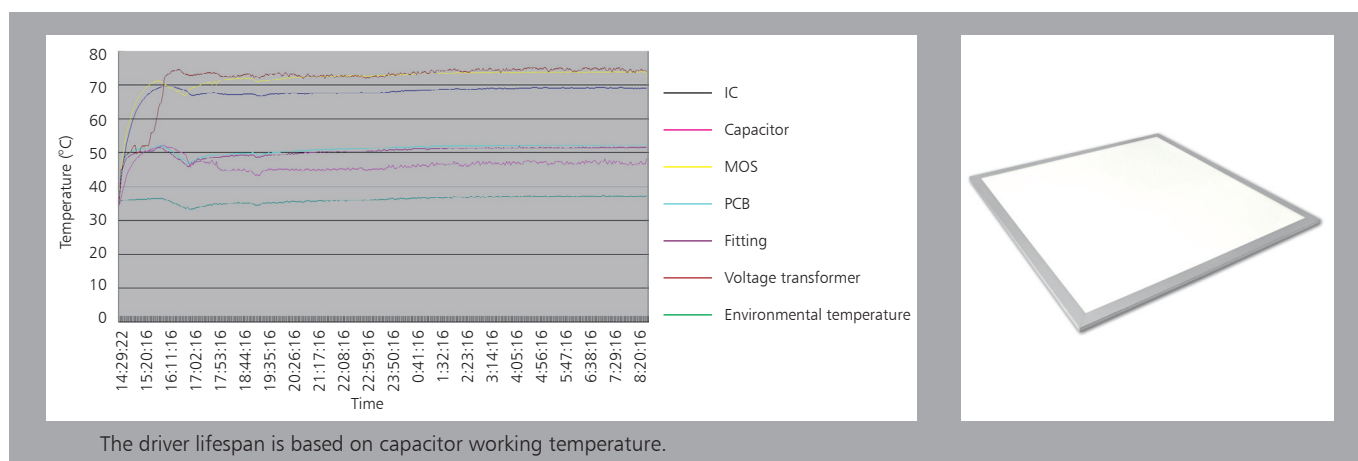

The driver lifespan is based on capacitor working temperature.

Installation

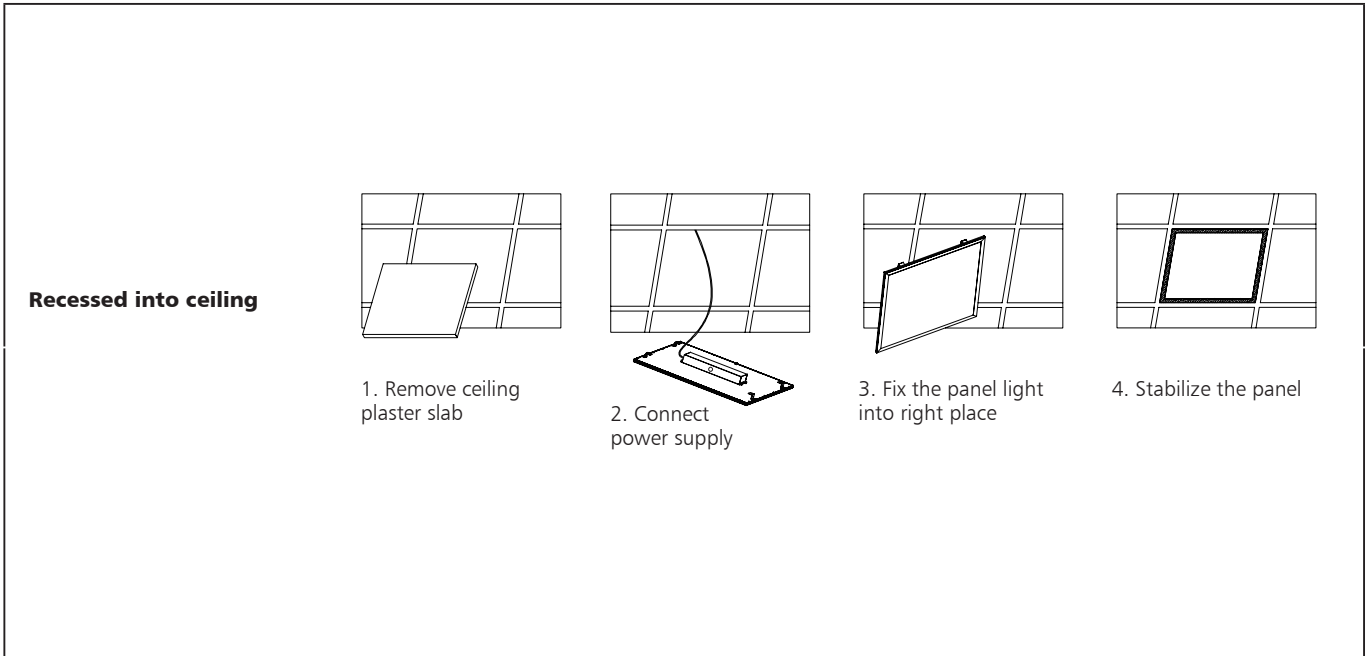

Packaging Information

	SIZE(CM)	N.W/pc (KGS)	G.W.(KGS)	Q'TY(PCS)
Carton	67.5*43*69.5	4.8	25.5	4

	CTNS	Q'TY(PCS)	VOLUME(CBM)
20" standard container	135	540	28
40" standard container	270	1080	56

